

## Serve Over Counter Brabant Range



### Product Description

The Trimco Brabant is a contemporary range of serveovers with stylish vertical flat front glass. The airflow of the unit is designed so you get even cooling over the whole deck but a fan is not required. This ensures food on display does not get dried out, the unit comes with refrigerated understorage as standard. The unit is finished in white with stainless rear serving shelf, deck and kick plates.



**BRABANT 150**

### Features and Benefits

- Fully automatic
- Static cooling
- Adjustable feet
- Interior light with switch
- Digital controller and temperature display
- Ambient shelf
- Hinged doors to refrigerated understorage
- 13 Amp socket to rear for scales/till etc.
- Stainless rear shelf
- Stainless deck
- Number of storage doors: 100 = 1, 150 = 1, 200 = 2, 250 = 3, 300 = 4

### Technical Specifications

Temperature Range	+2/+8°C
Refrigerant	R134a
Type of Defrost	Off Cycle
Exterior Finish	White
Interior Finish	Stainless Steel
Power Required	13 Amp
Max Ambient	25°C at 60% RH
Climate Class	3

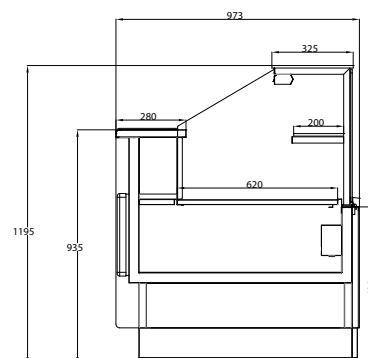

Model	Description	Dimensions (mm)			Kg	Total Display Area	Price	Next Day
		H	W	D				
<b>BRABANT 100</b>	White	Ext. 1195	953	973	190	0.64m <sup>2</sup>	<b>£1,649</b>	X
<b>BRABANT 150</b>	White	Ext. 1195	1453	973	216	0.98m <sup>2</sup>	<b>£2,074</b>	X
<b>BRABANT 200</b>	White	Ext. 1195	1953	973	324	1.32m <sup>2</sup>	<b>£2,540</b>	X
<b>BRABANT 250</b>	White	Ext. 1195	2453	973	390	1.67m <sup>2</sup>	<b>£3,210</b>	X
<b>BRABANT 300</b>	White	Ext. 1195	2853	973	432	1.94m <sup>2</sup>	<b>£3,765</b>	X